



PROJECT		REF		REV	ITEM CODE	
LOCATION		DATE			Page	

SANITARY WARE SPECIFICATION SHEET

Item Descriptions	Stern (Israel) "Elite SD Plus AISI316" Stainless steel AISI316 extended body liquid soap dispenser with built-in sensor in AC Supply with 5m wire AC 110-240 Vac 50/60Hz to 12V 2.5A IP68 waterproof switching transformer
Model	Elite Soap Dispenser Plus E AISI316
Code Number	236104
Finish	Stainless Steel AISI316
Supplier	Acme Sanitary Ware Co. Ltd Mr. Eric Wong/ Mr. Don Yuen
Contact Tel/Fax	(852) 2388-7171 / (852) 2710-8012
E-mail	acme@acmesanitary.com.hk
Website	www.acmesanitary.com.hk

ELITE SOAP DISPENSER PLUS E AISI316

Ref # 236104

Touch free electronic soap dispenser for deck mounted installations. Activated by infrared sensor. Stainless Steel AISI316 body, other finishes available. Includes a 1 liter soap bottle and bottle support. Optional for remote installation: extension cable and longer piping. The following functions can be performed by using Stern remote control: soap quantity selection, refill the soap tank, temporary off, coming back to factory settings

*Versions for multifeed installation available.

Application:

Closing automatically without dripping, Stern's touch free soap dispenser helps to ensure that the bathroom will stay organized and neat. Combined with Elite touch free electronic faucet, it creates a germ-free and automated environment.

Use:

Touch free electronic soap dispenser. The soap dispenser is activated automatically when the users bring their hands within the sensor range and stops when the users remove their hands.

PRODUCT SPECIFICATION	
Power supply	6D Alkaline battery*, plug-in transformer, output : 12 VDC 0.5A, or hardwired (1A/2.5A)
Soap:	non-proprietary, viscosity up to 3800 cP for liquid soap. Up to 100 cP for foam
Tank capacity:	33.8 oz (1L) bottle or 203 oz (6L) Tank/Bracket
Soap adjustability:	from 0.02 oz (0.7 ml) to 0.08 oz (2.3 ml)
Accessory	07100008 remote control for soap dispenser 07100009 remote control for foam dispenser
Detection range:	+/- 4"
Dispenser hole diameter	1" ~ 1-1/8" (25~29 mm)
Spare parts recommended:	
07220279	10-pack sensor kit
07222013	soap dispenser pump (liquid soap version)
07222026	pump + compressor kit (foam soap version)
06522080	12 V transformer
*batteries are not supplied	

Illustration/ Drawing

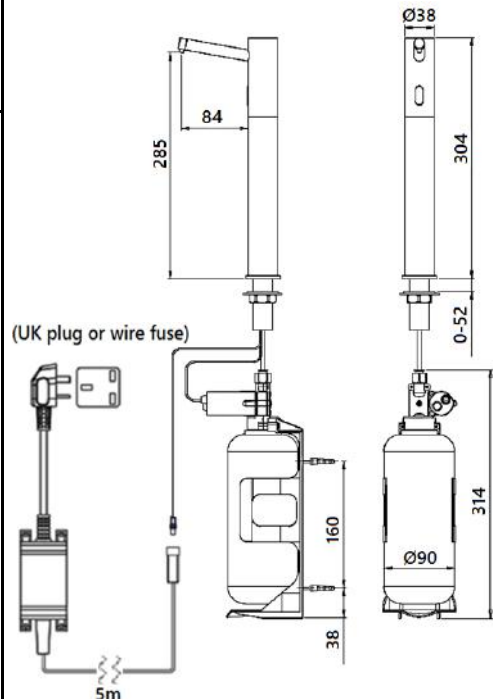

Installation:
Lavatory mounted

Power source:
12 V transformer

Stern Soap & Water:
Elite matching faucet

Default soap dosage:
1.4 cc

Soap viscosity:
100-3800 cPs



* All information of the above is for the reference only. No prior notice is made if any changes.



INSTALLATION

STEP 1 – REMOVE ALL MOUNTING HARDWARE

For TRENDY, ELITE, EXTREME, SMART, GREEN, GREEN 28 Soap Dispensers:

Drill a hole in the deck or lavatory according to the recommended hole size.

Remove the nut, the disk and the gasket from the base of the soap dispenser body.

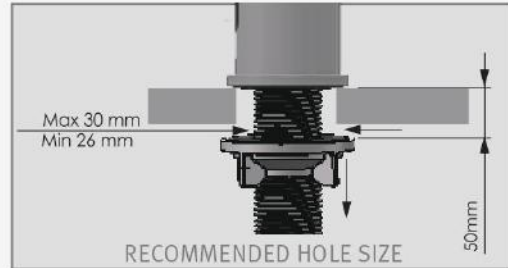

If your dispenser is supplied with anti-rotation solution, drill an additional hole for anti-rotation pin.

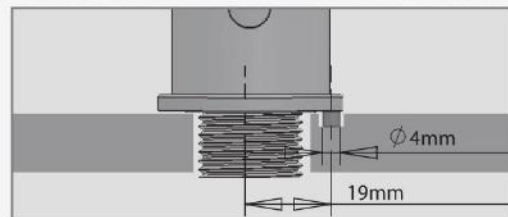

For CSABA Soap Dispenser:

Remove the hexagonal nut, disk and washer. Do not remove the O-ring from the base of the faucet.

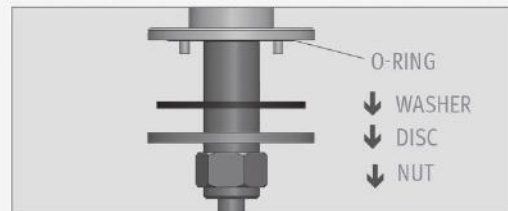

Drill a hole in the counter for the mixing handle. Remove the nut, disk and seal.



STEP 2 – INSTALLING THE SOAP DISPENSER

1

For TRENDY, ELITE, EXTREME, SMART, GREEN, GREEN 28 Soap Dispensers: Place the soap dispenser body along with the bottom ring into the hole in the deck or lavatory.

Slide the gasket, disk and nut over the soap dispenser body nipple and secure it.

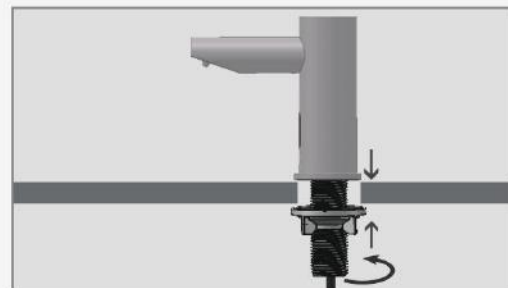

For CSABA Soap Dispenser:

Slide the washer, disk and hexagonal nut over the flexible hose and secure the faucet into place.

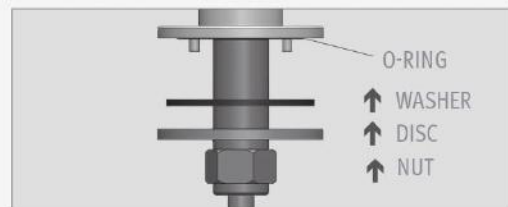



INSTALLATION

2

Fix the bottle with bottle support to the desired location.



3

Snap the soap pipe from the dispenser body into the quick connection fitting of the pump.



STEP 3 – CONNECTING THE POWER SOURCE

1

Remove the protective sticker covering the sensor. Keep away from the sensor range.

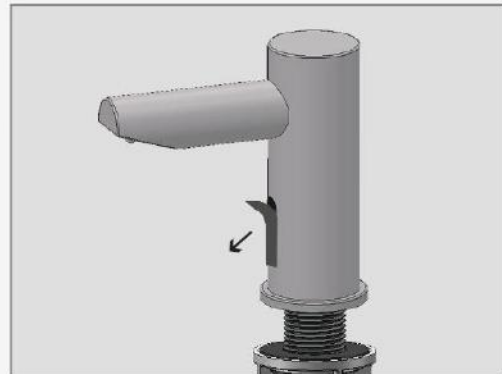

2

Connect the motor connector to its matching connector coming from the electronic unit. Please note that since the connector is water proof, some friction might apply.



O-RING VISIBLE – NOT CONNECTED PROPERLY



ONLY THE GROOVES ARE VISIBLE – CONNECTED PROPERLY



INSTALLATION

IMPORTANT: the 4 contacts connector should be connected properly so that the white o-ring is not visible and a clicking sound is heard.

PAY ATTENTION: If the 4 contacts connectors is not connected properly, the motor will work continuously.

2a

For battery versions: install the battery box on the wall underneath the sink and connect the battery connector.

Caution: make sure to connect the connectors according to the indication on the battery box sticker.



2b

For transformer versions: plug the transformer into the electricity socket and connect the transformer connector

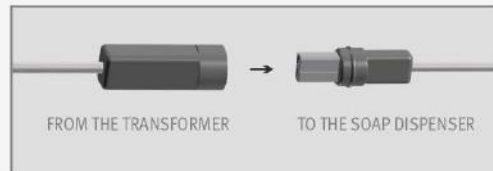

3

Wait about 10 seconds before you put your hands within the sensor range.





TROUBLESHOOTING

Indication	Investigation	Cause	Solution	Illustration
False activation: Soap dispensing	Continuous discharge from the nozzle	AUX connector not fully inserted	The connector should be inserted fully until white o-ring is not visible. Remove the o-ring if necessary	
	Random discharge from the nozzle	Reflection issue from other object	Eliminate any cause of reflection and if necessary use appropriate remote control to shorten detection range.	
	Soap discharging from pump housing.	Damaged pump due to high viscosity or debris in pipes	Replace the Pump. Rinse warm water through the pipe and the body of the soap dispenser all the way to the nozzle.	
Soap not dispensing	Pump is making sounds when sensor is activated	Soap tank is empty	Fill with soap with correct viscosity (100 - 3800 cPs) and prime pipes using the fill button on remote control.	
		Soap dispenser has not been primed	Prime the soap dispenser by pressing the fill button on the remote or by pressing the refill button located at the bottom of the pump, until soap exits the nozzle.	
		Damaged pump (discharge from housing)	Replace the Pump	
		Debris or dried soap in the pipe or tank	Run warm water through pipe, pump, and body all the way to the nozzle. Replace with soap of correct viscosity.	
		High viscosity soap (> 3800 cPs)	NOTE: Using the soap dispenser with high viscosity soap may cause permanent damage to the pump and shorten the lifecycle.	
		Bent pipes	Unbend or straighten pipes.	



TROUBLESHOOTING

Indication	Investigation	Cause	Solution	Illustration	
Soap not dispensing	Pump is not making sound when the sensor is activated	Sensor is blinking when hand is placed in front	AUX connector not fully inserted	The connector should be inserted fully until the white o-ring is not visible. Remove the o-ring if necessary	
		Refill button on pump does not activate the pump.	Replace the Pump. Rinse warm water through the pipe and the body of the soap dispenser all the way to the nozzle.		
		Damaged pump (discharge from housing).	Run warm water through pipe, pump, and body all the way to the nozzle. Replace with soap of correct viscosity. NOTE: Using the soap dispenser with high viscosity soap may cause permanent damage to the pump and shorten the lifecycle.		
		Debris or dried soap in the tank or tubing			
	Sensor is not blinking when hand is placed in front	Refill button on pump does not activate the pump.	Transformer: Check operation with functioning transformer. Where necessary replace with appropriate transformer. For part numbers see spare parts list.		
			Battery: Check operation with functioning battery pack. Where necessary, replace batteries or replace the battery pack: Battery pack (without batteries)		
		Reflection issue from other object	Eliminate any cause of reflection and use appropriate remote control to shorten detection range.		
		Damaged sensor	If the above two solutions have not resolved this issue replace with appropriate sensor. For part numbers see spare parts list.		